



Kooltherm®

HIGH DENSITY PRODUCTS FOR
LOAD BEARING APPLICATIONS



High Density Products Benefits & Advantages

- Class 0 fire rating for both phenolic and jacket.
- Negligible smoke emission.
- Best available thermal insulation properties.
- K Blocks have a cell structure which resists moisture absorption.
- CFC Free formulation provides the optimum energy saving and environmental solution in meeting current international agreements.
- Insulation values are significantly better than wood, calcium silicate or foam glass making it more cost efficient.
- Non-Fibrous.
- Excellent chemical resistance and does not support vermin or mould.
- Factory applied aluminium foil vapour barrier jacket with low emissivity for increased energy efficiency.
- Suitable for use in food processing, pharmaceutical, medical and other clean air environments.
- Treated with a specially formulated dust suppressant and passivating bore coating.
- Guaranteed for 10 years, if fitted in accordance with Kooltherm recommendations.



Kooltherm High Density Phenolic

DESCRIPTION

Kooltherm CFC Free phenolic is available in a range of high densities which are used to manufacture load bearing insulation inserts for pipework and ductwork supports. They are faced with a factory applied reinforced Class 0 aluminium foil barrier which matches that used on standard Kooltherm pipe insulation and Kooltherm duct insulation. Their use eliminates thermal bridging and facilitates sealing of the aluminium foil jacket to form a continuous vapour barrier which is particularly important on cold pipework and ductwork.

KOOLTHERM HIGH DENSITY PHENOLIC

A range of high density CFC Free phenolics which are used mainly in the design and manufacture of load bearing insulation supports for pipework, ducting and vessels. They have excellent fire resistance and extremely low smoke emission.

TYPICAL PROPERTIES

HIGH DENSITY PHENOLIC;				
Nominal Densities (kg/m ³)	60	80	120	160
Compressive Strength (kPa)				
Parallel to rise	400	650	1350	2300
Perpendicular to rise	270	400	950	1650
Thermal Conductivity at 10°C mean (W/mK)	0.028	0.031	0.033	0.036
Moisture Vapour Resistivity (MNs/gm)	360	360	360	360
Moisture Vapour Transmission (ug.m/Nh at 38°C, 88%rh)	10	10	10	10
Moisture absorption (ISO 2896/50mm head for 7 days)	5%	5%	5.5%	6.5%
Temperature Limits, all densities;	-180°C to +120°C			
BS 476 Part 7: surface spread of flame rating,	Class 1			
BS 476 Part 6: fire propagation				
Main Index	I<12			
Sub Index	i<6			
Building Regulations, Approved Document B,	Class 0			
BS 5111 Part 1: Smoke obscuration rating,	<5% (negligible)			
ASTM D3014 - Flammability - Weight retained,	85%			
ALUMINIUM FOIL VAPOUR BARRIER JACKET;				
Moisture Vapour Permeance (g/sMN)	0.0006			
Fire Rating	Class 0			

K BLOCK PIPE SUPPORT INSERTS

Standard Kooltherm K Block Pipe Support inserts are designed to be used in pipe hanger brackets and will support the compressive loads imposed by horizontal pipework carrying water or other liquids. Their use enables the specified thickness of insulation to be maintained at the pipe supports and facilitates the installation of a continuous and fully sealed vapour barrier which is particularly important on cold pipework.

Kooltherm K Blocks may be used to support all types of pipework operating up to a maximum continuous temperature of 120°C, including mild steel, stainless steel, copper and plastic pipes. They are available to suit all standard pipe sizes and thicknesses of insulation. Special sizes are available on request.

Load bearing calculations for the standard range of Kooltherm K Blocks are based on the minimum compressive strength of the relevant density of phenolic (ie: perpendicular to rise) and include a safety factor of 5 (Table 1). They are designed to support the maximum static compressive loads imposed by horizontal water filled mild steel (BS 1387 heavy grade) pipework and with hanger supports spaced at the maximum centres shown in Table 2.

CROCODILE STRIP - CIRCULAR DUCT SUPPORT INSERTS

Crocodile Strips are designed for use in air conditioning and ventilation circular ducting support brackets. They are manufactured from segments of high density phenolic fully adhered to a backing strip of reinforced aluminium foil vapour barrier jacket. Their use enables the specified thickness of insulation to be maintained at the duct support and facilitates the installation of a continuous and fully sealed vapour barrier which is particularly important on ductwork carrying cold air.

Crocodile Strips should not be used for water filled pipes.

Kooltherm K Blocks are not designed to accommodate pipe anchor loads and stresses.

Kooltherm K Blocks are manufactured to the dimensional tolerances shown in Table 3 & 4 and lengths shown in Table 1.

For pipework supported on roller supports the modified design of Roller Support Kooltherm K Block shown in Fig 4 should be used.

Fig. 1 (Installation of K Block)

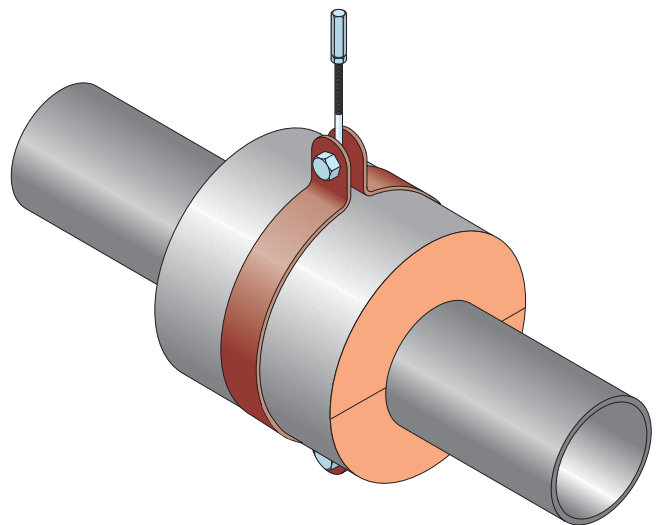
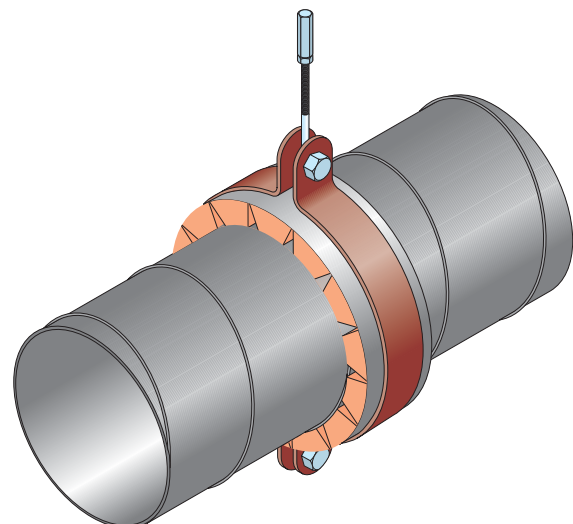

Fig. 2 (Installation of Crocodile Strips)



Availability			
Strip Lengths	1 metre		
Widths	50mm	75mm	100mm
Thickness	20mm and above		

Kooltherm High Density Phenolic

RECTANGULAR DUCT SUPPORT INSERTS

Duct Support Strips are designed for use in air conditioning and ventilation rectangular ducting support brackets. They are manufactured from flat strips of high density phenolic, fully adhered to a backing strip of reinforced aluminium foil vapour barrier jacket. Their use enables the specified thickness of insulation to be maintained at the duct support and facilitates the installation of a continuous and fully sealed vapour barrier, which is particularly important on ductwork carrying cold air.

Availability			
Strip Lengths	1 metre		
Widths	50mm	75mm	100mm
Thickness	20mm and above		

Fig. 3 (Installation of Duct Strips)

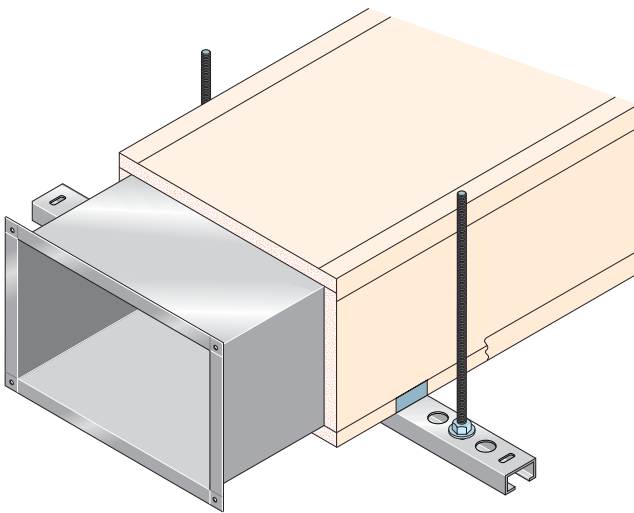

NOTE

Although they were originally developed to complement the Kooltherm range of pipe and duct insulation materials, the above products may also be used when other types of insulation are specified for temperatures up to 120°C.

Technical Data

TABLE 1

Nominal Pipe Size (*)	Pipe OD (mm)	K Block Length	Max. Load kg
1/2	21	99	12
3/4	27	99	15
1	34	99	19
1 1/4	42	99	23
1 1/2	48	99	27
2	60	99	33
2 1/4	76	99	62
3	89	99	73
4	114	99	94
5	140	99	115
6	168	124	410
8	219	124	534
10	273	124	666
12	324	200	1265
14	356	200	1389
16	406	200	1585
18	457	200	1784

TABLE 2: MAXIMUM SUPPORT CENTRES

Kooltherm support blocks have been designed to support pipes at the centre shown in the following table.

Nominal Pipe Size (*)	1/2	3/4	1	1 1/4	1 1/2	2	2 1/4	3	4	5	6	8	10	12	14	16	18
OD of Pipe (mm)	21	27	34	42	48	60	76	89	114	140	168	219	273	324	356	406	457
Max Support Centres (m)	3			4				6			4						

Special K Blocks can be manufactured for support centres greater than above, refer to Technical Department.

(SEE FOLLOWING PAGE FOR TABLE 3)

TABLE 4: STANDARD KOOLTHERM K BLOCK DIMENSIONS

Reference	NB inches	OD mm	Pipe Size Length of support	Metal Spreader	Insulation Thickness
Range 1	1/2 to 1 1/4	21 to 42	99mm	None	20-100mm
Range 2	1 1/2 to 5	48 to 140	99mm	1.0mm	20-100mm
Range 3	6 to 8	168 to 219	124mm	1.5mm	20-100mm
Range 4	10 to 18	273 to 457	200mm	2.0mm	25-200mm

Technical Data

TABLE 3 STANDARD KOOLTHERM K BLOCK DIMENSIONS (for selection of pipe support brackets)

NB			Kooltherm			NB			Kooltherm		
Imperial Steel Pipe	Pipe OD (mm)	Insulation Thickness (mm)	K Block OD (mm)	Imperial Steel Pipe	Pipe OD (mm)	Insulation Thickness (mm)	K Block OD (mm)	Metric Copper Tube	Pipe OD (mm)	Insulation Thickness (mm)	K Block OD (mm)
0.5"	21	15	52.5	4.0"	114	20	157.5	15mm	15	15	46.5
	21	20	52.5		114	25	167.5		15	20	56.5
	21	25	72.5		114	30	177.5		15	25	66.5
	21	30	82.5		114	40	197.5		15	30	76.5
	21	40	102.5		114	50	217.5		15	40	96.5
	21	50	122.5		114	50	217.5		15	50	116.5
0.75"	27	15	58.5	5.0"	140	20	183.5	22mm	22	15	53.5
	27	20	68.5		140	25	193.5		22	20	63.5
	27	25	78.5		140	40	223.5		22	25	73.5
	27	30	88.5		140	50	243.5		22	30	83.5
	27	40	108.5	6.0"	168	20	212.5		22	40	103.5
	27	50	128.5		168	25	222.5		22	50	123.5
1.0"	34	15	65.5	8.0"	168	30	232.5	28mm	28	15	59.5
	34	20	75.5		168	40	252.5		28	20	69.5
	34	25	85.5		168	50	272.5		28	25	79.5
	34	30	95.5		219	20	263.5		28	30	89.5
	34	40	115.5		219	25	273.5		28	40	109.5
	34	50	135.5		219	30	283.5		28	50	129.5
1.25"	42	15	73.5	10.0"	219	40	303.5	35mm	35	15	66.5
	42	20	83.5		219	50	323.5		35	20	76.5
	42	25	93.5		273	20	318.5		35	25	86.5
	42	30	103.5		273	25	328.5		35	30	96.5
	42	40	123.5		273	30	338.5		35	40	116.5
	42	50	143.5		273	40	358.5		35	50	136.5
1.5"	48	15	81.5	12.0"	273	50	378.5	42mm	42	15	73.5
	48	20	91.5		324	20	349.5		42	20	83.5
	48	25	101.5		324	22	379.5		42	25	93.5
	48	30	111.5		324	30	369.5		42	30	103.5
	48	40	131.5		324	40	409.5		42	40	123.5
	48	50	151.5		324	50	429.5		42	50	143.5
2.0"	60	15	93.5	14.0"	356	20	401.5	54mm	54	15	87.5
	60	20	103.5		356	25	411.5		54	20	97.5
	60	25	113.5		356	30	421.5		54	25	107.5
	60	30	123.5		356	40	441.5		54	30	117.5
	60	40	143.5		356	50	461.5		54	40	137.5
	60	50	163.5		16.0"	406	20		451.5	54	50
2.5"	76	20	119.5	406		25	461.5	67mm	67	15	100.5
	76	25	129.5	406		30	471.5		67	20	110.5
	76	30	139.5	406		40	491.5		67	25	120.5
	76	40	159.5	406		50	511.5		67	30	130.5
3.0"	89	20	132.5	18.0"		457	20	502.5	76mm	67	40
	89	25	142.5		457	25	512.5	67		50	170.5
	89	30	152.5		457	30	522.5	76		15	109.5
	89	40	172.5		457	40	542.5	76		20	119.5
	89	50	192.5		457	50	562.5	76		25	129.5
								76		30	139.5
								76	40	159.5	
								76	50	179.5	

FIG 4
Special
Roller
Support
Design

Side Elevation

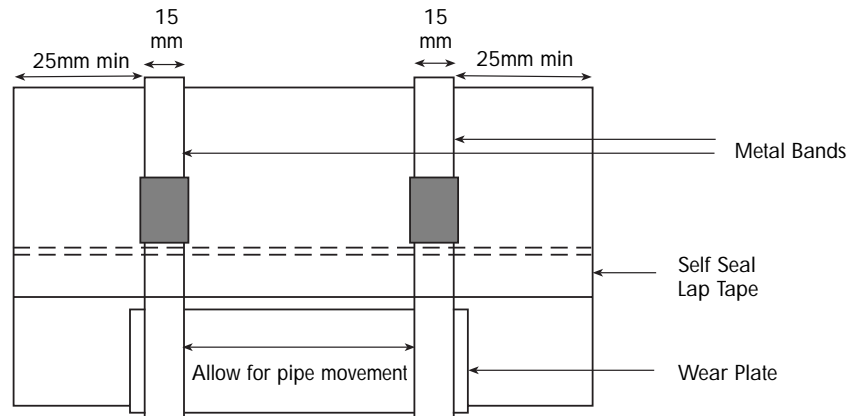

Metal Casings (Saddles) bonded to foam each half

End Elevation

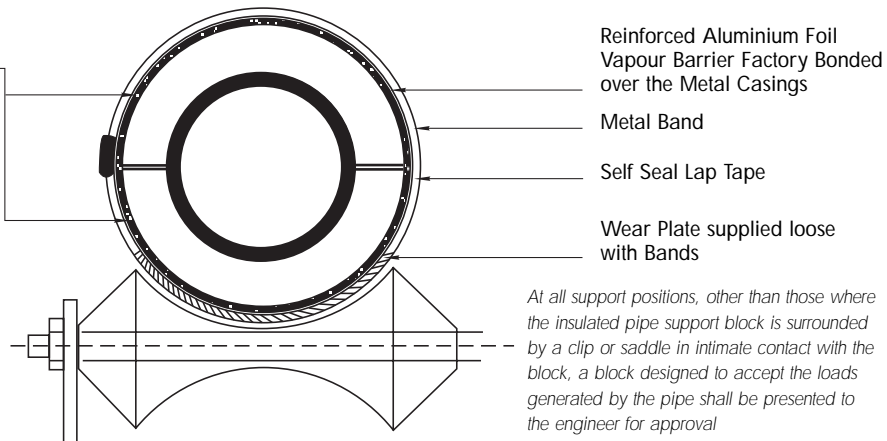

At all support positions, other than those where the insulated pipe support block is surrounded by a clip or saddle in intimate contact with the block, a block designed to accept the loads generated by the pipe shall be presented to the engineer for approval

FIG 5

Metal Casings (Saddles) bonded to foam each half

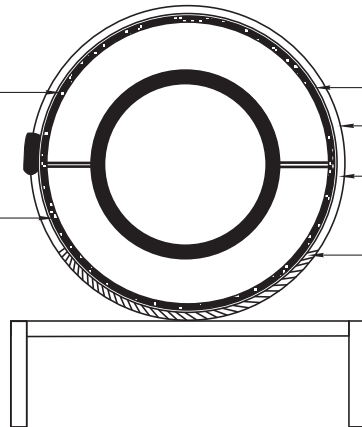

Reinforced Aluminium Foil Vapour Barrier Factory Bonded over the Metal Casings
Metal Band
Self Seal Lap Tape
Wear Plate supplied loose with Bands

The values given against these properties are typical. They are not meant to imply specification limits and should not be used for this purpose without reference to Kingspan Industrial Insulation.

This brochure cancels and supersedes all previous editions. Kingspan Industrial Insulation reserves the right to amend specifications without prior notice.

Whilst the information contained in this brochure is true and accurate to the best of our knowledge and belief, all liability for errors and omissions, damage or loss resulting herefrom is hereby excluded.

Recommendations for use should be verified as to suitability and compliance with actual requirements, specifications and any applicable laws and regulations.